



» OPERADOR CORREDIZO MARCA CAME MOD.BK.

BK

SLIDING GATE AUTOMATION



CONNECT



THREE-PHASE RIO SYSTEM 2.0



DUTY CYCLE

UP TO 22 CYCLES/HOUR

MAXIMUM LEAF WEIGHT

UP TO 2200 kg

MAXIMUM LEAF LENGTH

UP TO 23 m



Solution for large sliding gates

- Available with module 4 or 6 pinion.
- Ready for installation of magnetic limit switches.
- Control board with terminal blocks, display and storage for up to 250 users.
- The safety inputs can be configured to directly control the 8k2Ω resistive sensitive-safety edges.
- Self-diagnosing safety devices.
- 230 - 400 V AC three-phase version for 2200 Kg model.
- Developed with CONNECT technology for remote digital control via gateway or locally via CAME KEY.

Dimensions (mm)

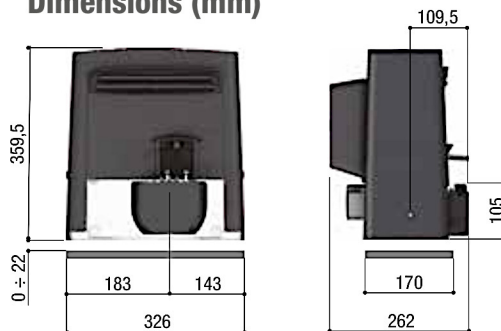

Operational limits

MODELS	801MS-0070	801MS-0080	801MS-0090	801MS-0100	801MS-0120	801MS-0130
Max. length of leaf (m)	20	20	20	20	20	23
Max. weight of leaf (kg)	800	1200	1800	2200	2200	2200
Pinion module	4	4	4	6	4	6

Technical characteristics

MODELS	801MS-0070	801MS-0080	801MS-0090	801MS-0100	801MS-0120	801MS-0130
Protection rating (IP)	44	44	44	44	44	44
Power supply (V - 50/60 Hz)	230 AC	230 AC	230 AC	230 AC	230 AC	230/ 400 V AC THREE PHASE
Power supply to motor (V)	230 AC	230 AC	230 AC	230 AC	230 AC	230/ 400 V AC THREE PHASE
Absorption (A)	4,5	3,3	4,2	5,1	5,1	1,5
Power (W)	520	380	480	580	580	520
Manoeuvring speed (m/min)	10,5	10,5	10,5	10,5	10,5	10,5
Cycles/Hour	14	14	14	14	22	14
Thrust (N)	800	850	1150	1500	1500	1650
Operating temperature (°C)	-20 ÷ +55	-20 ÷ +55	-20 ÷ +55	-20 ÷ +55	-20 ÷ +55	-20 ÷ +55
Motor's heat protection (°C)	150	150	150	150	150	150

• 230 V AC • 230 - 400 V AC THREE PHASE

